

Z6.320

SPECIFICATIONS

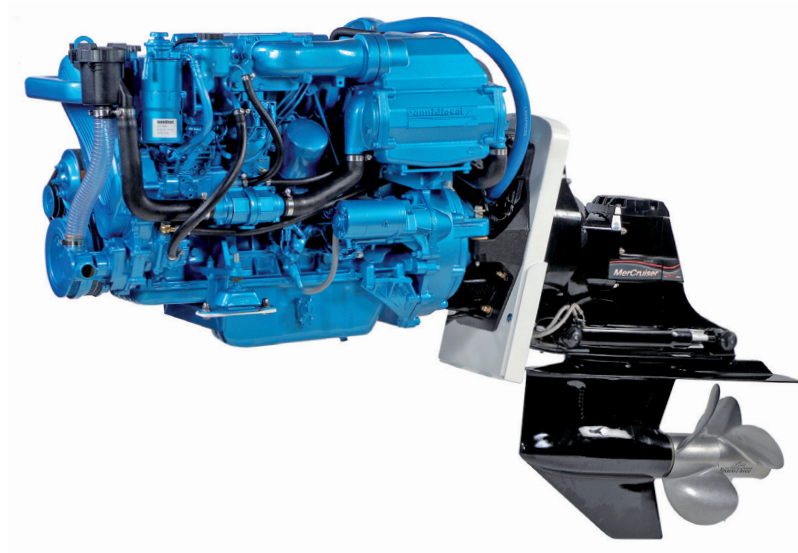

Power at crankshaft	235.5 kW [320 hp]	Engine base	Toyota
Displacement	4.2 l [254 in ³]	Fuel system	Direct injection Mechanical controlled
Configuration	6 cylinders in line	Air intake	Turbocharged with intercooler
Operation type	4 strokes Diesel	Cooling	Closed cooling with heat exchanger
Bore & Stroke	94 x 100 mm [3.7 x 3.94 in]	Max mounting angle	0° Front down 7° Front up
Compression ratio	15.7 : 1	Alternator	12 Volt 80 Amp
Rated speed	3600 rpm	Rating	M6
Idling speed	700 rpm	Emission compliance	BSO2
Peak torque	804 Nm	Dry weight with Bravo X Three	552 kg [1217 lbs]
Peak torque speed	2400 rpm		

Z6.320

235.5 kW [320 hp] at 3600 rpm

TECHNICAL DESCRIPTION

ENGINE BLOCK

- 6 Cylinders in line
- 4 Valves per cylinder
- Water-cooled exhaust manifold
- Balancing shafts

FUEL SYSTEM

- Direct injection, mechanical controlled
- Mechanically primed fuel filter

LUBRICATION SYSTEM

- Replaceable full-flow oil filter
- Oil dipstick
- Oil cooler

COOLING SYSTEM

- Closed cooling with heat exchanger
- Gear driven self-priming raw water pump
- Coolant circulating pump
- Water cooled exhaust elbow

ELECTRICAL SYSTEM & INSTRUMENTATION

- 12 V / 80 A Alternator
- 12 V starter motor
- Complete instrumentation including key switch and alarms
- Extension cable harness

AIR INTAKE

- Water-cooled turbocharger
- Intercooler

OTHER FEATURES

- Flexible engine mounting

OPTIONAL EQUIPMENTS & ACCESSORIES

- Complete marine propulsion systems
- Marine transmission adaptation kits
- Throttle and shift controls
- Additional instrumentation, Flying bridge extension harness
- Water boiler systems
- Stuffing box connections
- Complete exhaust systems
- Trolling valve
- Two pole electrical system

RATINGS

- Up to 500 annual operating hours
- Load factor up to 35%
- Full power for no more than 30 minutes out of each 8 hours of operation. The remaining time must be at, or below cruising speed

TRANSMISSIONS

STERN DRIVE

- Bravo XR One
- Bravo XR Two
- Bravo XR Three
- Contact your Nanni representative for more details and availability about transmissions types and models range.

PERFORMANCE CURVES

POWER AT CRANKSHAFT

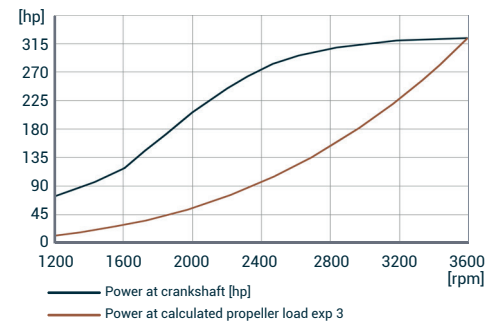

TORQUE AT CRANKSHAFT

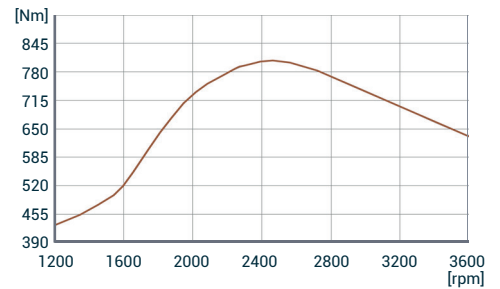

FUEL CONSUMPTION

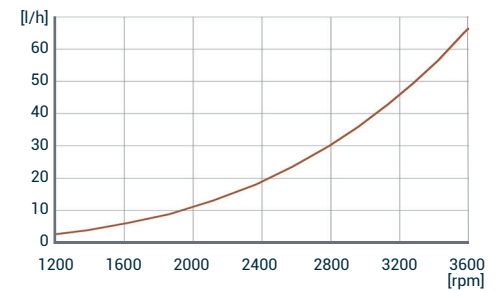

DIMENSIONS WITH BRAVO XR THREE

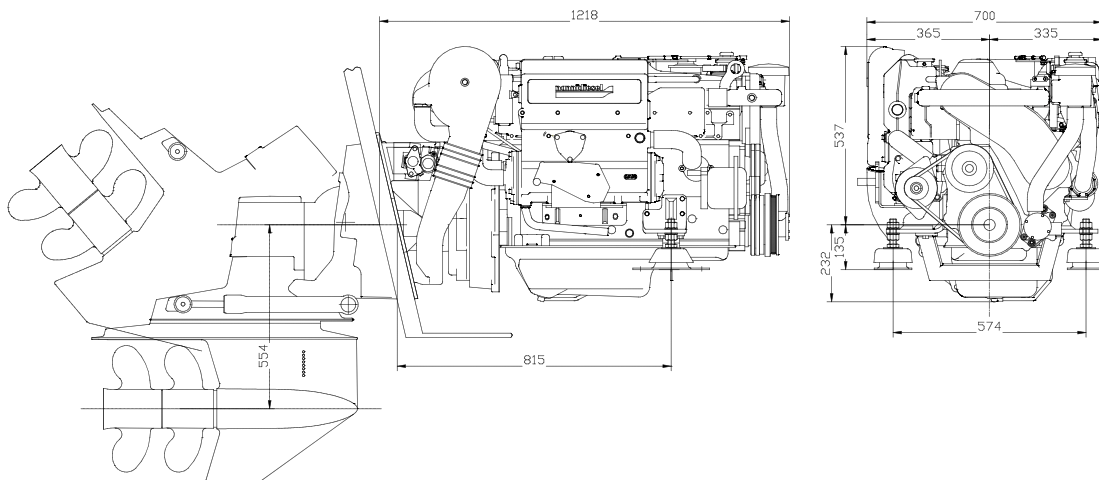

NANNI AUSTRALIA

26/17-21 Bowden Street Alexandria,
NSW. 2015
Tel: +61 (0)2 9319 5222
engines@nannidiesel.com.au

Find a Nanni dealer near you at

www.nannidiesel.com.au

Technical data according to ISO 8665. This document is not contractual. Nanni reserves the right to modify any of the characteristics stated in this document without notice, in a constant effort to improve the quality of its products. Images and illustrations may show non standard equipments. All combination of equipment & accessory are not available.

DGBXXC01018A